

Hills Antenna UHF/VHF Antenna Model: 01TBUV5-4G

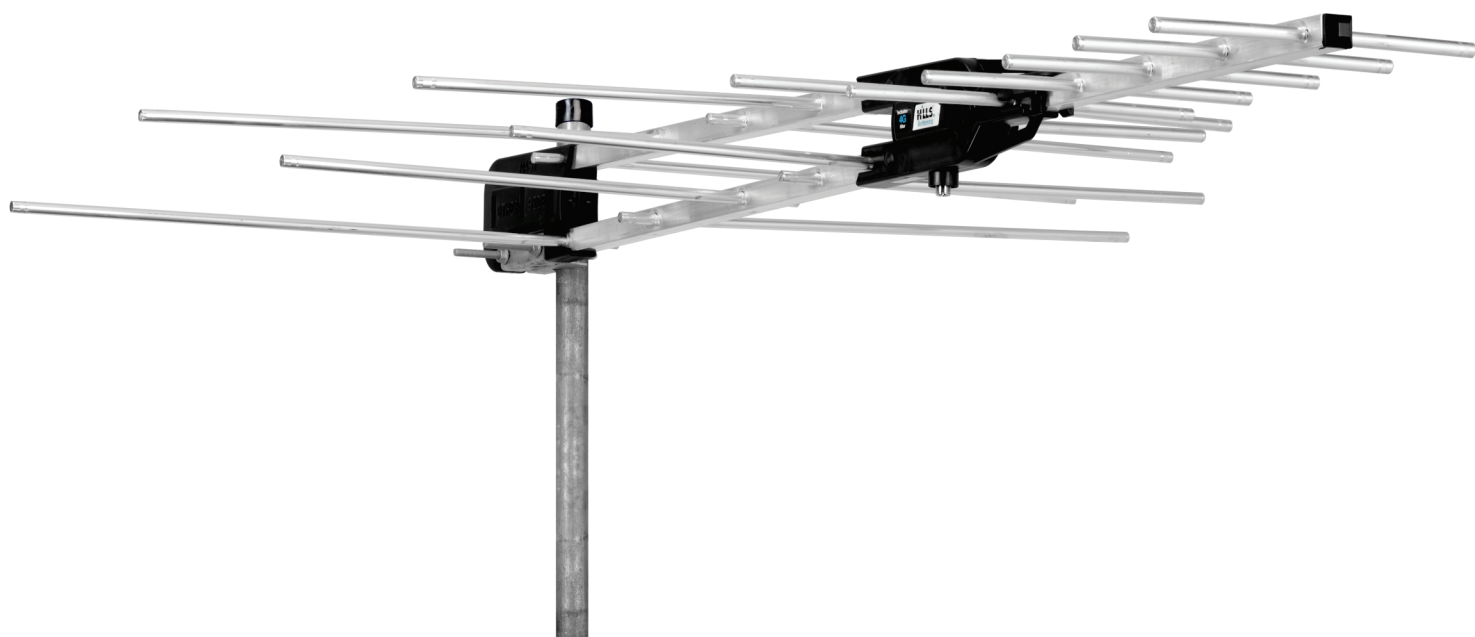

Product Description:

The Hills Antenna 01TBUV5-4G Tru-Band UHF/VHF 5 Element Antenna is a revolutionary range of antennas specifically designed for the digital-only TV environment in Australian Capital Cities and certain regional areas serviced by VHF or VHF/UHF transmitters. The Tru-Band Silver Bullet provides the gain required for all prime locations and is built to provide a lifetime of trouble-free viewing. This new edition of the Tru-Band Antenna now features an individually tuned and optimised RF filter circuit. Specifically designed with shielded inductors, to better withstand any potential 4G/5G transmission interference from the growing number of mobile towers. The Silver Bullet model combines the sleek, low impact look with prime reception qualities to ensure you receive the picture you deserve, without compromising the aesthetic of your home. Designed and manufactured in Australia with unmatched quality and a Lifetime Warranty, you simply cannot go wrong with this antenna. It is suitable for both domestic and commercial applications.

Features and Benefits:

- Designed for the precise digital frequency bands for true HD performance
- Boomlock™ manufacturing technology developed and patented by Hills
- Matched balun for best MER performance and lowest insertion loss
- Ultrasonically sealed balun prevents water ingress for maximum reliability
- Strong mechanical construction, lightweight and compact
- Made from aluminium for superior corrosion resistance
- Designed for Australian channels
- Channels 6-12 and 28-38
- 4G/5G filter included
- Lifetime Manufacturer Warranty included

Specifications:

- Antenna Category: UHF/VHF
- Antenna Type: Yagi/Log Periodic
- Antenna Elements: 5 UHF & 5 VHF
- Antenna Band: Band 3 (Ch 6-12) & Band 4/5 (Ch 28-38)
- Antenna Filter: 4G/5G >60dB
- Antenna Max Gain: UHF 6-8dBi & VHF 5-7dBi
- Antenna Front to Back Ratio: UHF 16-20dB & VHF 12-14dB
- Antenna Materials: Aluminium, UV Stabilised Plastics
- Antenna Dimensions: 900 x 835 x 85mm (L x W x H)
- Antenna Colour: Silver
- Unit Packaging: Box
- Warranty: Lifetime

Included Accessories:

- Sealing Boot (For F Connector),
- V Block & U Bolt fitted to antenna



Hills Antenna UHF/VHF Antenna Model: 01TBUV5-4G

Product Features.

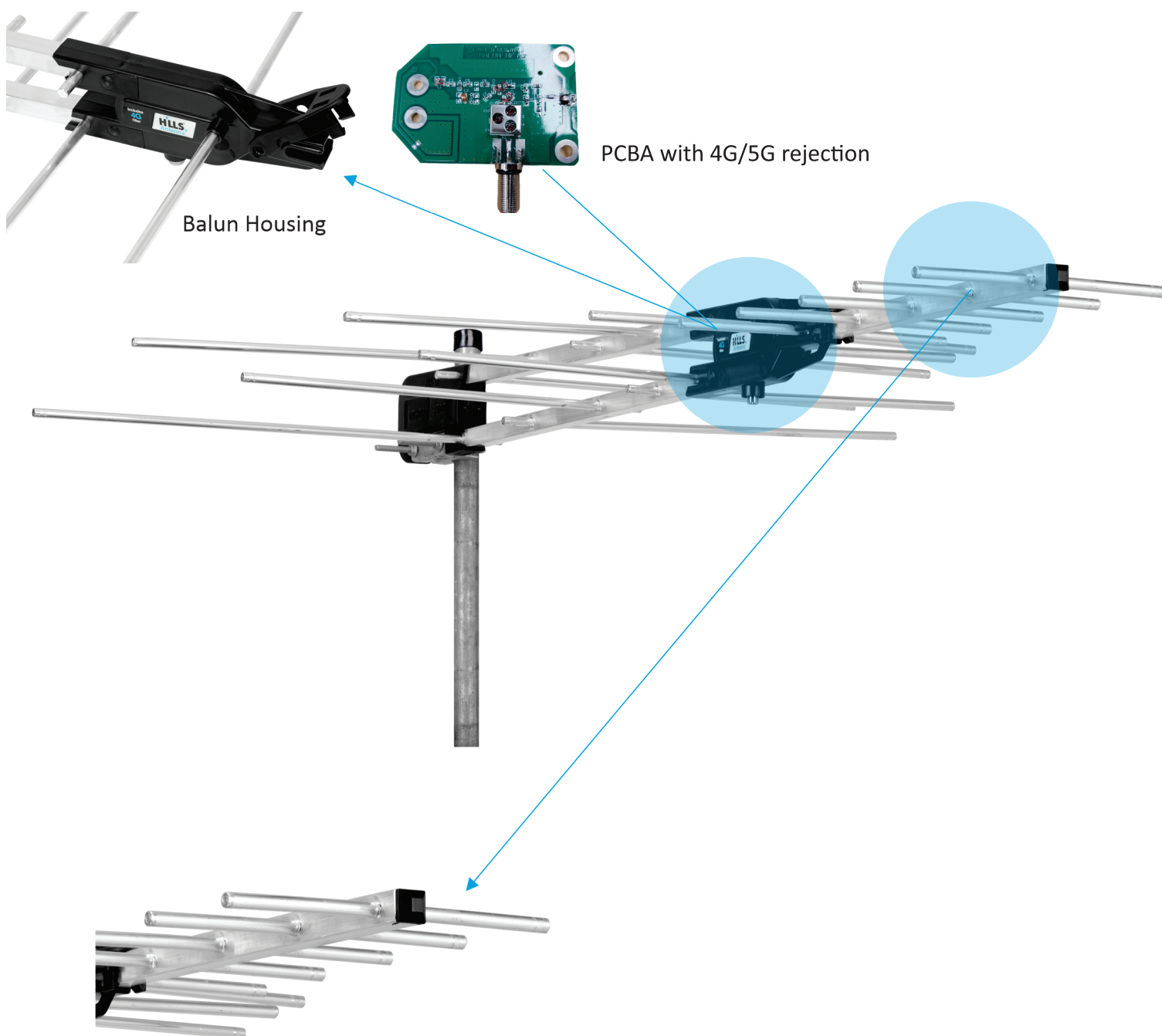

Patented Boomlock™ Technology

Performance Characteristics.

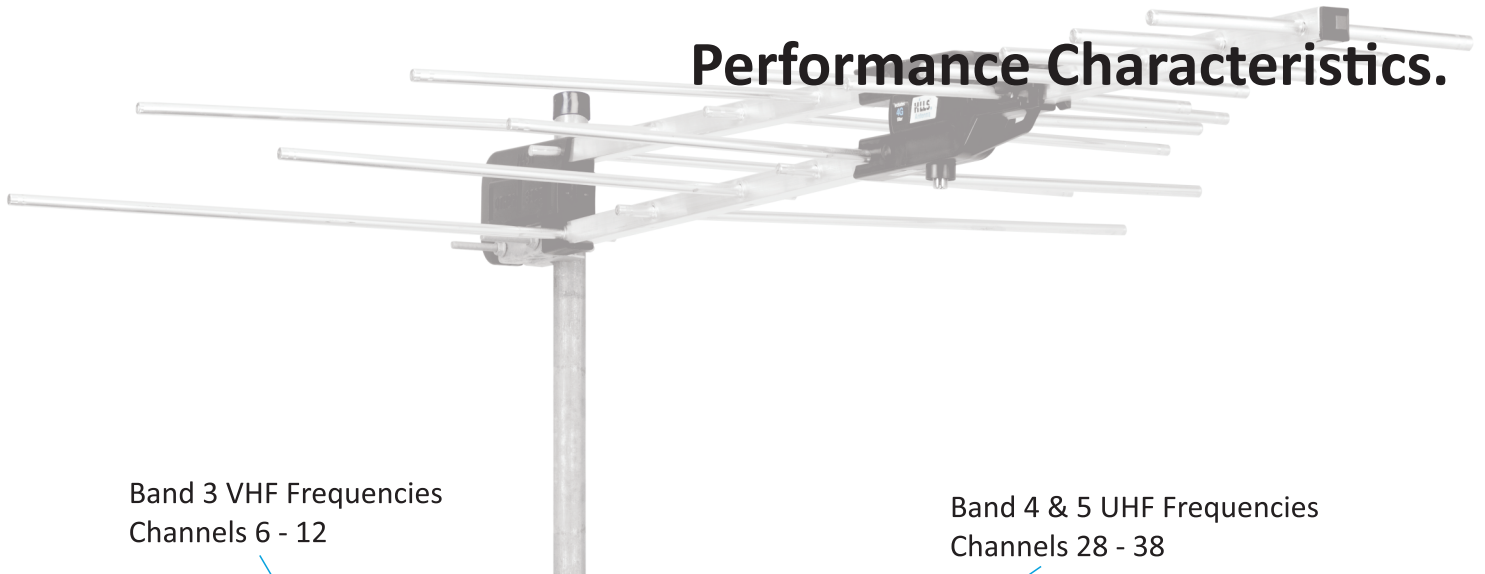

Band 3 VHF Frequencies
Channels 6 - 12

Band 4 & 5 UHF Frequencies
Channels 28 - 38

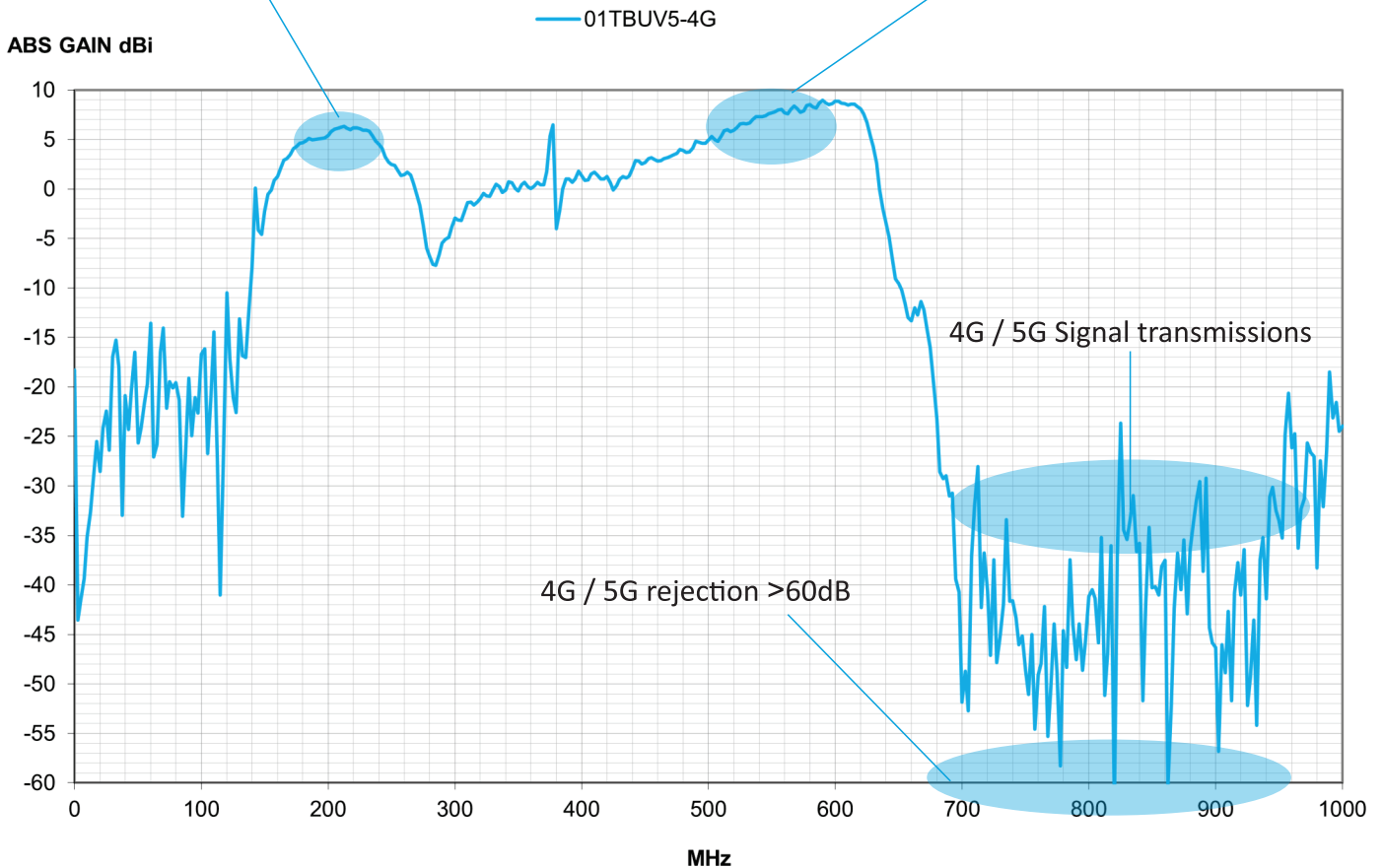

www.bitek.com.au

Available From

National Phone: 1300 601 915
Email: orders@bitek.com.au

Bitek Pty Ltd
11 Sheppard Street
Hume
ACT 2620
Ph: 02 6260 1874

Bitek (Syd) Pty Ltd
Unit 7, 463 Victoria Street
Wetherill Park
NSW 2164
Ph: 02 9659 2272

Bitek (Vic) Pty Ltd
22 Constance Court
Epping
VIC 3076
Ph: 03 9456 9222

Bitek (SA) Pty Ltd
1 Temple Court
Ottoway
SA 5013
Ph: 08 8395 4111